

## Firmware V1.02 new functions

### Changing the term "scene" to "folder"

Until now, the level beneath projects had been called scenes, but since now it is possible to change the names of takes freely after recording, the term "scene" is no longer suitable.

For this reason, what had been called a "scene" before is now called a "folder". Buttons and screen references have also been changed. For example, the Folder Name button and the FOLDER NAME screen.

However, the default folder name has not changed and is still Scene plus three digits.

- The Folder Name button (formerly, the Scene Name button) and the 1st Folder (formerly, 1st Scene)

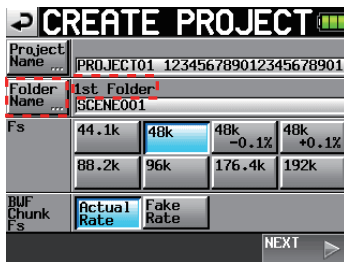

CREATE PROJECT screen 1

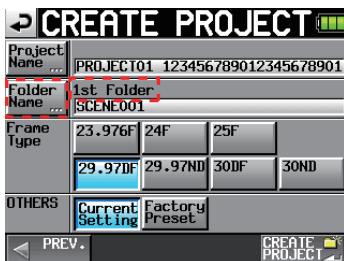

CREATE PROJECT screen 2

- 1st FOLDER screen (formerly, 1st SCENE NAME screen)



1st FOLDER screen

- MAKE FOLDER button (formerly, MAKE SCENE button)

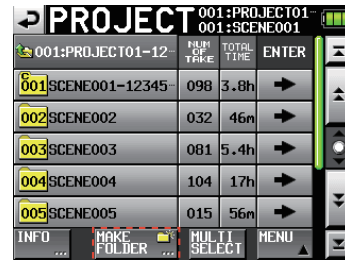

Folder selection screen

- MAKE FOLDER screen (formerly, MAKE SCENE screen)



MAKE FOLDER screen

- NUM OF FOLDER (formerly, NUM OF SCENE) display

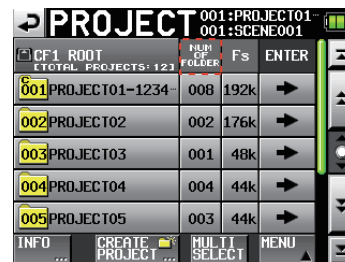

Project selection screen

In addition, when reading the Owners Manual, please replace the term "scene" with the term "folder".

### Addition of project number, folder number and take number indications

Numbers have been added to projects, folders and takes, and these numbers are now displayed.

Project numbers are assigned to projects in the order that they are saved on the media. Folder numbers are assigned in order as they are created inside each project. Take numbers are assigned in order as they are saved in a folder.

#### ■ Take number display on the Home screen

The take number is now shown in front of (to the left of) the time counter.

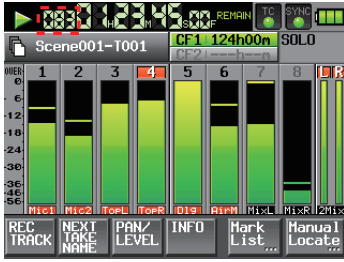

Home screen

■ Each number is shown on the project selection screen, folder selection screen and take selection screen

The numbers are shown on the icons displayed in the list on each selection screen.

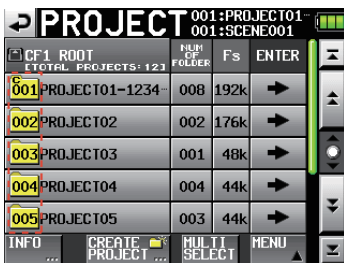

Project selection screen

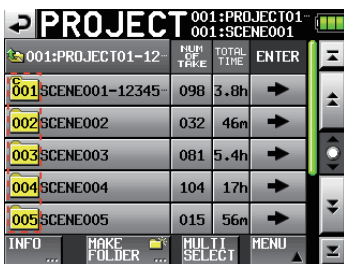

Folder selection screen

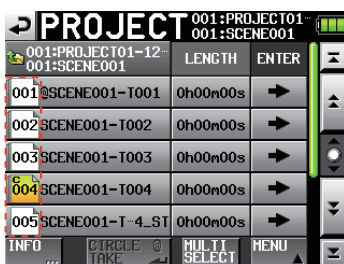

Take selection screen

- Folder name editing screen when creating a new folder
- Project name editing screen when editing a project name
- User word editing screen when editing the next take name

1. To use this button, open the screen where you can edit the project name, for example, as shown below.



Project name editing screen

2. Press the Date button to replace the name with the date set in the internal clock in the yyyy-mm-dd format.



Project name editing screen

**NOTE**

- If the same project name or folder name already exists, an “\_” (underscore) followed by an unassigned number is added.
- After pressing the “Date” button and replacing the name with the date, you can further edit the name on this screen. (The name of an already created folder cannot be edited later.)

**Next Take Name editing function added**

A NEXT TAKE NAME button has been added to the Home Screen. Press this button to open a NEXT TAKE NAME pop-up window where you can edit the name given to takes. This change will be applied to the next recorded take.

■ Take name first half

The first half of the take name can be set to either UserWord or FolderName.

**NOTE**

The first half of the take name can only be edited when the unit is stopped.

**Addition of a date input button**

A Date button has been added to screens where project names, for example, are edited. This new function allows the date set in the internal clock to be inserted into the name.

The following screens have had a Date input button added.

- Project name editing screen when creating a new project
- 1st folder name editing screen when creating a new project

- **UserWord mode (button)**  
Select this to use the user name as the first half of the take name. Press the **EDIT** button to open the screen where you can edit the user word. (This is like the project name editing screen.)



- **FolderName mode (button)**  
Select this to use the folder name as the first half of the take name. This is the default setting.



**Take name second half**

The second half of the take name is made of one alphabetical letter and three numerical digits. Press the **EDIT** button to open an editing screen where you can set the one letter. You can also set the three numbers by using the “-” and “+” buttons. (This functions in the same way as the **NEXT TAKE** function accessed by the **REC TRACKS** button (Ⓜ). See “2 – Names and functions of parts” in the Owner’s Manual for details.)

**NOTE**

- Since the “Next Take Name” setting is saved by project, if the project is changed, that project’s setting will be used.
- The numerical portion of the second half of the take name can be changed even during playback and recording. (The first half of the take name and the letter in the second half can only be changed when the unit is stopped.)
- If the first half of the take name or the letter in the second half is different, it is now possible to create takes that have the same three digits in the latter half.

**Mono file recording folder selection**

When the file mode is set to **MONO** mode, you can now select from two types of folders for recording audio files. The default setting is **SubFolder**.

**NOTE**

In either mode, subfolders are created for each take inside folders, and this is where the management files are generated.

**SubFolder mode**

In the same way as before, subfolders are created for each take inside folders, and recorded audio files are saved in them.

**Folder mode**

Recorded audio files are saved directly inside the folder.

**NOTE**

- Whether the file mode is set to “Poly” or “Mono,” when Folder mode is selected, the maximum number of takes that can be recorded in one folder might be significantly less than usual in some cases. For this reason, the following pop-up window opens when switching to Folder mode, warning that the maximum number of takes will be reduced.



Moreover, the following pop-up window opens when switching back to SubFolder mode to let you know that the maximum number of takes has been increased again



- During recording, if you press the **REC** key to try to start the next take, the next take can be recorded 4 seconds after starting recording when in poly mode or mono subfolder mode. In folder mode, however, some cases will take more than 4 seconds.

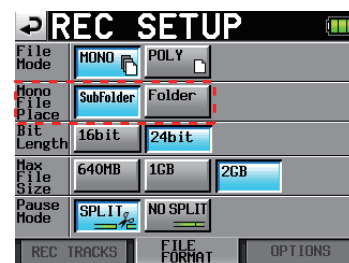

The folder structure shown in “8 – Transferring Data between the Unit and a Computer” has been changed to the following. In addition to these files, management files and folders are also created.

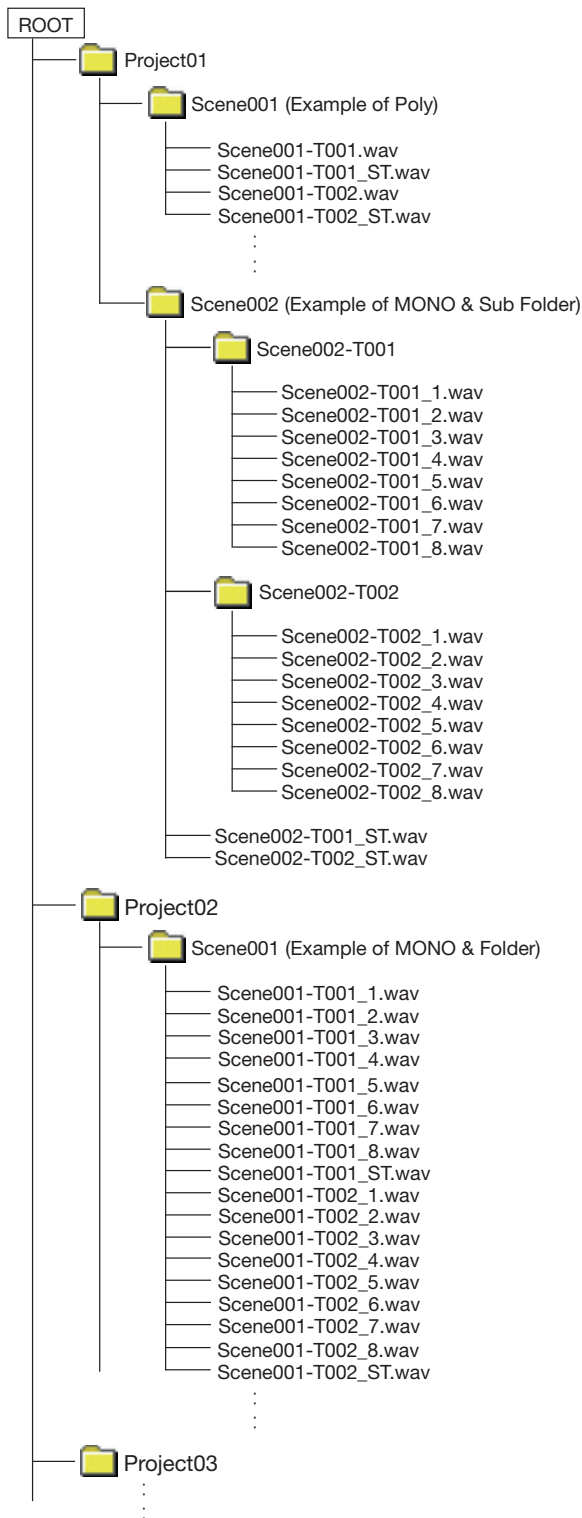

- Poly: When the File Mode is set to POLY (there is no Mono File Place setting)
- MONO & Sub Folder: When the File Mode is set to MONO and Mono File Place is set to Sub Folder
- MONO & Folder: When the File Mode is set to MONO and Mono File Place is set to Folder

## Limitations to recording operations

This unit can only handle a total of about 2000 items, including files and subfolders, inside one folder. If this limit is exceeded, further recording to that folder will not be possible. In this case, the following types of things will occur.

- If the **REC** key is pressed during recording, the unit might not be able to start recording a new take. In this case, the following pop-up messages will appear.

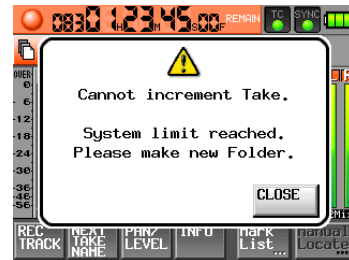

- When loading a project or folder, recording to that folder might not be possible. In this case, the following pop-up messages will appear.



Moreover, in these cases, the Home Screen will show Rec Limit for the remaining recordable time of the currently selected CF card.

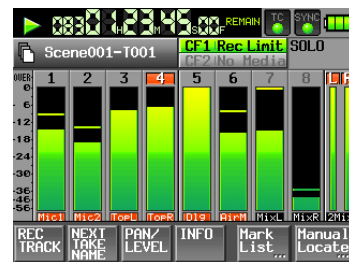

### NOTE

The limit on the total number of items in one folder includes files and folders not created by the unit. Moreover, this total also includes management files, system files and other files and folders that are not normally visible.

## Change of the default reference level

With this version of the firmware, the default reference level has been changed from -16 dB to -20 dB. (See “PREFERENCES page” on page 46 of the Owner’s Manual.)

## New functions added in firmware V1.04

### Mid-side (MS) microphone connection mode added

The unit can now decode signals from MS microphones. In addition to decoding as it records, the unit can also record without decoding and then decode during playback.

#### Setting the MS decoding mode

Set the MS decoding mode on the **SETUP** page of the **MIXER SETUP** screen.

To open the **MIXER SETUP** screen, press the **MENU** key to open the **MENU** screen and touch the **MIXER SETUP** button.

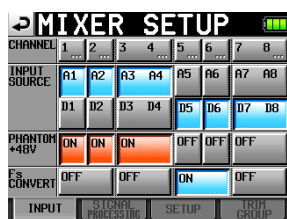

On this page, touch the **SETUP** tab to open the **SETUP** page.

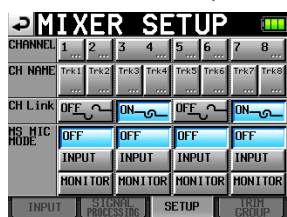

Use the **MS MIC MODE** item to set the decoding mode when connecting MS microphones. This can be set for each channel pair (1-2, 3-4, 5-6 and 7-8) separately.

#### OFF (default):

In the default mode, this function is off during recording and playback.

#### INPUT:

Use this mode to decode while recording.

Decoding is not applied during playback.

#### MONITOR:

When MS mic signals are being recorded without decoding in order to be decoded later, use this mode to decode just for monitoring while recording.

Use this mode also when playing back takes that were recorded using an MS mic without decoding.

#### NOTE

- When either **INPUT** or **MONITOR** is on, channel link is also turned on for the corresponding pair of channels, and the **CH LINK** button for the pair becomes blue. When **INPUT** and **MONITOR** are turned off, channel link is not turned off. When **INPUT** or **MONITOR** are turned on for a pair of channels, touching the **CH LINK** button to turn off the channel link will also turn off the **INPUT** or **MONITOR** setting.
- During recording or playback, the **MS MIC MODE** setting cannot be changed. Always stop the unit before changing the setting.

#### Connecting a mid-side microphone

To use this unit's MS decoding function, connect the mid to the odd channel and the side to the even channel. If the mid and side are connected in reverse, decoding will not be conducted correctly.

For example, connect mid to CH3 and side to CH4.

#### Conduct MS decoding during recording

- On the **SETUP** page of the **MIXER SETUP** screen, set the **MS MIC MODE** to **INPUT** for the pair of channels connected to the MS microphone.
- Push the **HOME** key to open the Home Screen and touch the **PAN/LEVEL** button to open the screen where you can make adjustments with the pan pots and level knobs.



The **PAN** knobs on the channel pairs that have **MS MIC MODE** set to **INPUT** become MS balance knobs that adjust the width of the sound.

- Touch the **PAN** knob (MS balance knob) for the channel pair that you went to adjust, so that its background appears white.
- Use the **DATA** dial to adjust the width as desired in a range between 0 and 100 (default: 50). 50 is 100% mid. As the number becomes larger, the amount of side increases with 100 being 100% side.

#### NOTE

Values set are saved with the project even when the MS decode mode is off (**MS MIC MODE** set to **OFF**). When you set the MS decode mode to **INPUT** again, the settings made before turning decoding off will be used.

- Use the **2MIXLVL** knob to adjust the decoder output. Touch the **2MIXLVL** knob for the pair of channels that you want to adjust, so that its background appears white. Use the **DATA** dial to adjust the level as desired.

#### NOTE

You can also adjust the MS balance and output level on the **CHx-x SETUP** screen.



#### Recording without MS decoding

You can record a take without decoding (recording the mid and side signals as is) and then decode it during playback.

By decoding during playback, the recording will be output as a stereo mix.

To record without decoding, set the decode mode to **OFF** or **MONITOR**. When set to **MONITOR**, you can monitor with decoding even when the sound is recorded without it.

Adjust the MS balance and output in the same manner as when recording with decoding. (The recorded files are not decoded.)

## Trim group function addition

This new trim group function allows you to adjust input trim levels of multiple channels at the same time with one input trim knob set as the master

### NOTE

Along with the addition of the trim group function, the Function Key Assign item on the RC-F82 page of the REMOTE SETUP screen has a new MIXER (TRIM GROUP) setting.

### Setting trim groups

To use trim group operation, you must assign one channel as the master of the group and other channels as slaves.

There are four groups, and multiple combinations are possible.

### NOTE

- You cannot assign a channel to more than one group. The channel is always assigned to the last group selected.
- Only the input trim knob of the designated master can be used to adjust the input level. Turning the knobs of the slaves will have no effect.

- Press the MENU key to open the Menu Screen, and press the MIXER SETUP button to open the MIXER SETUP screen.
- Touch the TRIM GROUP tab to open the TRIM GROUP page.



The TRIM GROUP item contains buttons numbered 1-4 for each channel. Touch the corresponding buttons to assign each channel to groups 1-4.

In this example, we will make channel 1 the master for group 1 and channels 2, 3-4 (link), 5 and 6 into slaves.

- Under the channel that you want to make the master, touch the number button (1-4) for a group that does not have any channels assigned to it yet.

The letter M appears to the right of the number and the button becomes red.

In the example, touch the 1 button beneath channel 1. 1M appears and the button becomes red.

### NOTE

The first channel assigned to a group becomes its master. The master cannot be changed afterwards. If you want to change the master, clear the grouping and start again, assigning the channel that you want as the master to the group first.

- Touch the group number button under the channel that you want to make a slave. The button becomes blue. Slaves can be channels of numbers lower than the master and channels that are not consecutive. For example, if you press the 1 button under channel 2, that button becomes blue. Likewise, you can press the 1 buttons under channels 3-4, 5 and 6 and they will also become blue, indicating that they are slaves.
- By turning the input trim knob for channel 1, you can adjust the trim values for channels 2, 3-4, 5 and 6 together.

### NOTE

- If the trim setting for any of the grouped channels reaches its maximum or minimum value, continuing to turn the input trim knob of the master in the same direction will have no further affect on any of the channels. (The differences in values between channels are preserved.)
- Channels cannot be linked if they are in different groups (including when one is not in a group). Touching the button for those channels in the CH LINK item will cause the following pop-up warning to appear.



### Clearing a trim group

To clear a trim group, touch the master button for that group (the button that appears red and has the letter M next to the group number).

A pop-up appears to confirm that you want to clear the group.



Touch the OK button or press the DATA dial to clear the group. Doing this clears the group setting from the slaves (channels with blue buttons) at the same time.

If you try to assign a channel that is a group master to another group, a pop-up appears to confirm that you want to clear its group and assign it to a different group. Touch the OK button or press the DATA dial to clear the previous group and assign the channel that had been its master to the other group.



## Zero trim function added

Turning an input trim knob to its minimum setting now results in that channel being muted.

Each trim knob functions the same as before, but when it reaches its minimum setting, the channel is muted regardless of the reference level setting.

## New functions in firmware V1.10

### Mirror recording function added

A mirror recording function has been added that allows you to record simultaneously to 2 CF cards.

In order to make the mirror recording setting easy to see on the screen, indicators have been added to the CF card remaining time display button on the Home Screen. These indicators show the status of both CF cards: recording possible, recording not possible, or not ready for recording.

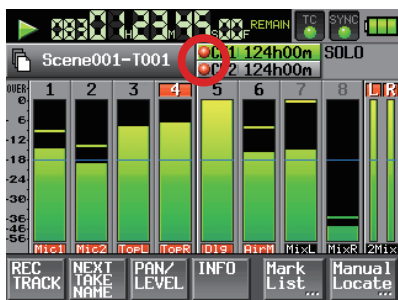

Home Screen during playback

#### Indicator meaning

- Recording possible
- Not ready for recording
- Recording not possible

#### Examples of CF card remaining recording time button indicators

##### ① When set to Single

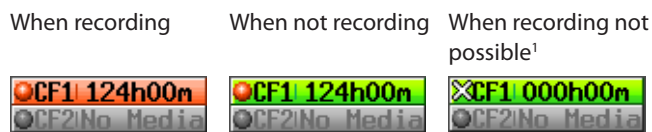

##### ② When set to Mirror



##### ③ When set to Mirror/Mirror disabled<sup>2</sup>

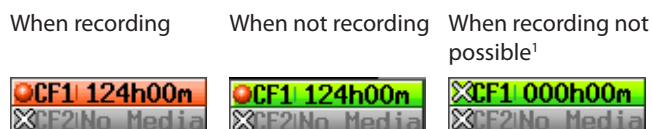

### Mirror recording settings

A REC MODE page has been added to the REC SETUP screen. This page has a REC Mode item that has Single and Mirror buttons.

**Single:** Recording can only be made to the currently selected CF card (default setting).

**Mirror:** 2 CF cards can be recorded to simultaneously.

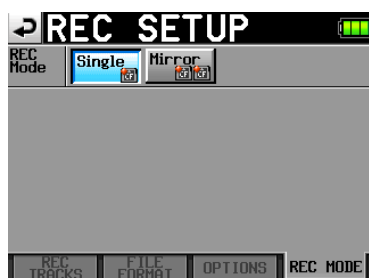

#### NOTE

If the sampling frequency of the current project is 88.2, 96, 176.4 or 192 kHz, the REC Mode setting is always set to Single and cannot be changed.

#### Setting button display

##### ① When set to Single



##### ② When set to Mirror



##### ③ When set to Mirror/Mirror disabled



#### 1) Conditions that make recording not possible

- Current CF card has no remaining capacity
- Current CF card not loaded
- Current CF card is not supported (PIO mode)
- Current CF card format is not supported (not FAT16 or FAT32)
- If a take with the same name as set on the NEXT TAKE NAME page and numbered 999 exists on either of the CF cards ("---" appears in the take number area on the Home Screen, NEXT TAKE NAME page)
- The total number of entries (files and folders) in the current folders of both CF cards exceed the system limits (CF card remaining time display button shows "Rec Limit")

#### 2) Conditions that disable mirror recording

- Non-current CF card has no remaining capacity (recording not possible if the current CF card has no open space<sup>1</sup>)
- Non-current CF card is not loaded (recording not possible if the current CF card is not loaded<sup>1</sup>)
- Non-current CF card is not supported (PIO mode) (recording not possible if the current CF card is not supported<sup>1</sup>)
- Non-current CF card format is not supported (not FAT16 or FAT32) (recording not possible if the current CF card is an unsupported format<sup>1</sup>)
- One of the CF cards is not compatible with UDMA
- One of the CF cards has not been formatted by this unit (not formatted with the cluster size recommended for this unit)
- If any of the above conditions apply, mirror recording will not occur, but recording to the current CF card will occur.

#### NOTE

- When set to Mirror, a project/folder will be created on the unselected CF card to match the current project/folder on the current CF card. When you start mirror recording, takes with the same name will be recorded to the projects/folders of the same name on both CF cards.
- If you retake when set to Mirror, only the take on the current CF card will be erased. The take on the other CF card will not be erased.

- When set to **Mirror**, if recording is not possible on the current CF card, recording will not occur on the other CF card either, regardless of its remaining space.
- During mirror recording, if the time counter display mode is **TOTAL REMAIN**, the amount of recording time possible when set to **Mirror** is shown (in other words, the time available on the CF card with the least amount of open space). During mirror recording, if one of the CF cards runs out of space, the amount of time that can be recorded on the CF card that is still being recorded to is shown.

## Mirror recording messages

- If the **REC Mode** is set to **Mirror** when mirror recording is not possible, one of the following messages appears.

### ① When recording not possible to one of the CF cards



### ② When one of the CF cards is not compatible with UDMA



### ③ When one of the CF cards was not formatted by this unit



- If recording is started when **Mirror** recording is disabled, one of the following messages appears.

### ① When **Mirror** recording is disabled for a reason other than ② or ③ below



### ② When one of the CF cards is not compatible with UDMA



### ③ When one of the CF cards was not formatted by this unit



- During mirror recording, if one of the CF cards runs out of remaining space or has an error, recording to that CF card will stop. Recording of the current take to the other CF card will stop, but recording of a new take as a new file will start immediately.

When this happens, a message will appear and the CF card remaining time display buttons will be shown as follows

### ① When one CF card runs out of open space



CF card remaining time buttons



### ② When an error occurs with one CF card



CF card remaining time buttons





## Recording times when set to mirror recording

Since mirror recording has a high processing load, the unit cannot write to a CF card fast enough when the card's remaining capacity becomes low, so it is not possible to write to the media until it is completely full. For this reason, compared to single recording, the possible recording time is shorter. Moreover, when mirror recording, the processing load also increases when the number of recorded files is great, so the possible recording time is shorter when using monophonic file mode compared to when using polyphonic mode.

### When set to single recording

File format and number of tracks	CF card capacity		
	8 GB	16 GB	32 GB
16-bit, 44.1 kHz, 8 tracks	3 hours 8 minutes	6 hours 17 minutes	12 hours 35 minutes
16-bit, 44.1 kHz, 8 tracks + stereo mix	2 hours 30 minutes	5 hours 2 minutes	10 hours 4 minutes
16-bit, 48 kHz, 8 tracks	2 hours 53 minutes	5 hours 46 minutes	11 hours 34 minutes
16-bit, 48 kHz, 8 tracks + stereo mix	2 hours 18 minutes	4 hours 37 minutes	9 hours 15 minutes
24-bit, 44.1 kHz, 8 tracks	2 hours 5 minutes	4 hours 11 minutes	8 hours 23 minutes
24-bit, 44.1 kHz, 8 tracks + Stereo mix	1 hour 40 minutes	3 hours 21 minutes	6 hours 42 minutes
24-bit, 48 kHz, 8 tracks	1 hour 55 minutes	3 hours 51 minutes	7 hours 42 minutes
24-bit, 48 kHz, 8 tracks + Stereo mix	1 hour 32 minutes	3 hours 4 minutes	6 hours 10 minutes
24-bit, 88.2 kHz, 8 tracks	1 hour 2 minutes	2 hours 5 minutes	4 hours 11 minutes
24-bit, 96 kHz, 8 tracks	0 hour 57 minutes	1 hour 55 minutes	3 hours 51 minutes
24-bit, 176.4 kHz, 4 tracks	1 hour 2 minutes	2 hours 5 minutes	4 hours 11 minutes
24-bit, 192 kHz, 4 tracks	0 hour 57 minutes	1 hour 55 minutes	3 hours 51 minutes

### When set to mirror recording/monophonic file mode

File format and number of tracks	CF card capacity		
	8 GB	16 GB	32 GB
16-bit, 44.1 kHz, 8 tracks	3 hours 4 minutes	6 hours 13 minutes	12 hours 30 minutes
16-bit, 44.1 kHz, 8 tracks + stereo mix	2 hours 26 minutes	4 hours 57 minutes	10 hours 0 minute
16-bit, 48 kHz, 8 tracks	2 hours 49 minutes	5 hours 42 minutes	11 hours 29 minutes
16-bit, 48 kHz, 8 tracks + stereo mix	2 hours 14 minutes	4 hours 33 minutes	9 hours 11 minutes
24-bit, 44.1 kHz, 8 tracks	2 hours 2 minutes	4 hours 8 minutes	8 hours 20 minutes
24-bit, 44.1 kHz, 8 tracks + Stereo mix	1 hour 37 minutes	3 hours 18 minutes	6 hours 40 minutes
24-bit, 48 kHz, 8 tracks	1 hour 52 minutes	3 hours 48 minutes	7 hours 39 minutes
24-bit, 48 kHz, 8 tracks + Stereo mix	1 hour 29 minutes	3 hours 2 minutes	6 hours 7 minutes

### When set to mirror recording/polyphonic file mode

File format and number of tracks	CF card capacity		
	8 GB	16 GB	32 GB
16-bit, 44.1 kHz, 8 tracks	3 hours 8 minutes	6 hours 17 minutes	12 hours 35 minutes
16-bit, 44.1 kHz, 8 tracks + stereo mix	2 hours 30 minutes	5 hours 1 minutes	10 hours 3 minutes
16-bit, 48 kHz, 8 tracks	2 hours 53 minutes	5 hours 46 minutes	11 hours 34 minutes
16-bit, 48 kHz, 8 tracks + stereo mix	2 hours 18 minutes	4 hours 37 minutes	9 hours 14 minutes
24-bit, 44.1 kHz, 8 tracks	2 hours 5 minutes	4 hours 11 minutes	8 hours 23 minutes
24-bit, 44.1 kHz, 8 tracks + Stereo mix	1 hour 40 minutes	3 hours 21 minutes	6 hours 42 minutes
24-bit, 48 kHz, 8 tracks	1 hour 55 minutes	3 hours 51 minutes	7 hours 42 minutes
24-bit, 48 kHz, 8 tracks + Stereo mix	1 hour 32 minutes	3 hours 4 minutes	6 hours 9 minutes

- The above recording times are estimates. They may differ depending on the CF card being used.
- The above recording times are not continuous recording times. They are the total amounts of recordable time on the CF card.
- When mirror recording, the sampling frequency of the recorded file cannot be 88.2, 96, 176.4 or 192 kHz

## Slate on status can now be retained

Previously, the signal from the slate mic or the slate tone (built-in oscillator) was only assigned to the armed tracks while the **SLATE** key on the front panel was being pushed. Now, if you press the **SLATE** key while pressing and holding the **SHIFT** key, the SLATE function can be turned ON indefinitely.

This operation can not be performed from the RC-F82 (fader unit designed for the HS-P82).

## Addition of take end time code display

End time code information (END T/C) has been added to the take information pop-up.

## New pop-up messages added in HS-P82 V1.10

Message	Details and responses	Remarks
Cannot Change Now Fixed in current Fs.	The current sampling frequency cannot be changed.	
CF1 Media Full. CF1:Stopped. CF2:still RECORDING.	Because CF1 does not have enough space, recording to it has stopped. Recording to CF2 is continuing.	This occurs when the REC Mode is set to Mirror.
CF1 Record Error. CF1:Stopped. CF2:still RECORDING.	Because an error occurred when recording to CF1, recording to it has stopped. Recording to CF2 is continuing.	This occurs when the REC Mode is set to Mirror.
CF2 Media Full. CF1:still RECORDING. CF2:Stopped.	Because CF2 does not have enough space, recording to it has stopped. Recording to CF1 is continuing.	This occurs when the REC Mode is set to Mirror.
CF2 Record Error. CF1:still RECORDING. CF2:Stopped.	Because an error occurred when recording to CF2, recording to it has stopped. Recording to CF1 is continuing.	This occurs when the REC Mode is set to Mirror.
Initializing ...	The card is being initialized.	
Mirror REC is not available. (CFn is not available)	Since the media cannot be used, mirror recording is disabled.	This occurs when the REC Mode is set to Mirror. n = 1 or 2
Mirror REC is not available. CFn formatting not optimal for Recording.	Because the media was not formatted by this unit, recording properly cannot be guaranteed, so mirror recording is disabled. Format the media with this unit to use it.	This occurs when the REC Mode is set to Mirror. n = 1 or 2
Mirror REC is not available. CFn not recommended type for Recording. (not UltraDMA)	Because this card does not meet the required system specifications, recording properly cannot be guaranteed, so mirror recording is disabled.	This occurs when the REC Mode is set to Mirror. n = 1 or 2

## The wordings of the following pop-up messages have changed.

Old message	New message	Details and responses	Remarks
CFn not recommended format for Recording/Playing.	CFn formatting not optimal for Recording/Search.	Because the media was not formatted by this unit, recording/searching properly cannot be guaranteed, so mirror recording is disabled. Format the media with this unit to use it.	n = 1 or 2 This occurs when the card is formatted with a cluster size that is smaller than specified by this unit.
CFn not recommended for Recording/Playing. (not UltraDMA)	CFn not recommended type for Recording/Search. (not UltraDMA)	Because this card does not meet the required system specifications, recording/searching properly cannot be guaranteed.	n = 1 or 2



